

# ACCESSORIES

IGD provide a range of accessories to enhance the performance of your Gas Detection System by catering to an applications specific needs. Whether this is detecting lighter than air gases, providing additional IP Protection for sensors or adding safety features to assist the quick evacuation of personal from gas hazards.



- ▶ **GAS COLLECTOR CONES & HOODS**  
Available to fit all IGD Gas Detectors. They are typically used when detecting lighter than air gases to enhance detection capability at specific points where leaks are likely to occur
- ▶ **CALIBRATION KITS & GAS BOTTLES**  
IGD provide gas calibration kits and replacement gas bottles to support our range of gas detectors.
- ▶ **SPLASH GUARDS**  
Splash Guards provide additional IP Protection for detectors where splashes, dust or draughts are a concern.
- ▶ **ATEX JUNCTION BOXES**  
ATEX Junction Boxes allow you to mount IGD 102 or MKIII Series ATEX Sensors in Zone 1 and 2 explosive areas and Zone 21 and 22 dust environments or provide extra break out terminals.
- ▶ **BEACON SOUNDERS**  
Provide visual and audible signals to assist in alerting personnel and aiding evacuation in the event of a Gas Alarm.
- ▶ **REMOTE GASSING PORT**  
Designed to allow easier bump testing or calibration of detectors located in hard to access locations
- ▶ **REMOTE RESET BUTTONS**  
Allow users to remotely reset or mute a gas alarm activation without going back to the control panel.
- ▶ **DUCT ADAPTERS**  
Are designed to allow monitoring of gas streams inside duct work or tank head spaces.
- ▶ **PIPE IN PIPE ADAPTOR**  
Designed to enable detectors to monitor the interstitial gap in double containment pipe systems.

# GAS COLLECTOR HOODS

Gas Collector Hoods are used where gas detection is required over a larger area than can be covered using a collector cone or where multiple collector cones would be impractical. The hoods are supplied in multiples of 0.5M up to 2.5M long. They are usually suspended using catenary wire above the equipment to be monitored for lighter than air gas escapes.

Hoods can be used with samplers or any IGD diffusion style detector such as TOC-750 or TOC-750X.

Note in the case of ATEX detectors, the detector must be separately supported.

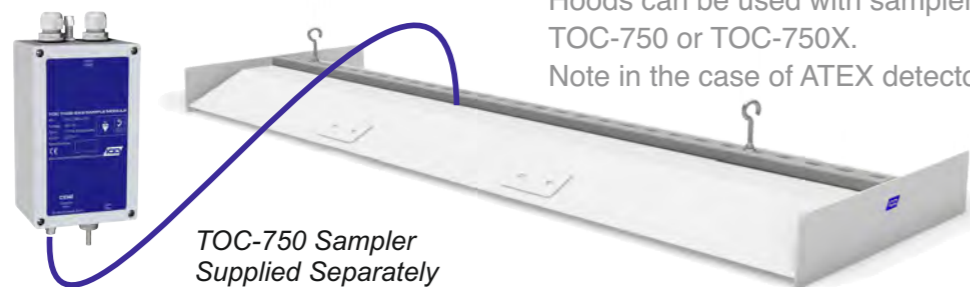

TOC-750 Sampler Supplied Separately

Detector Fitted with gas collector cone and remote gassing facility

## DIMENSIONS

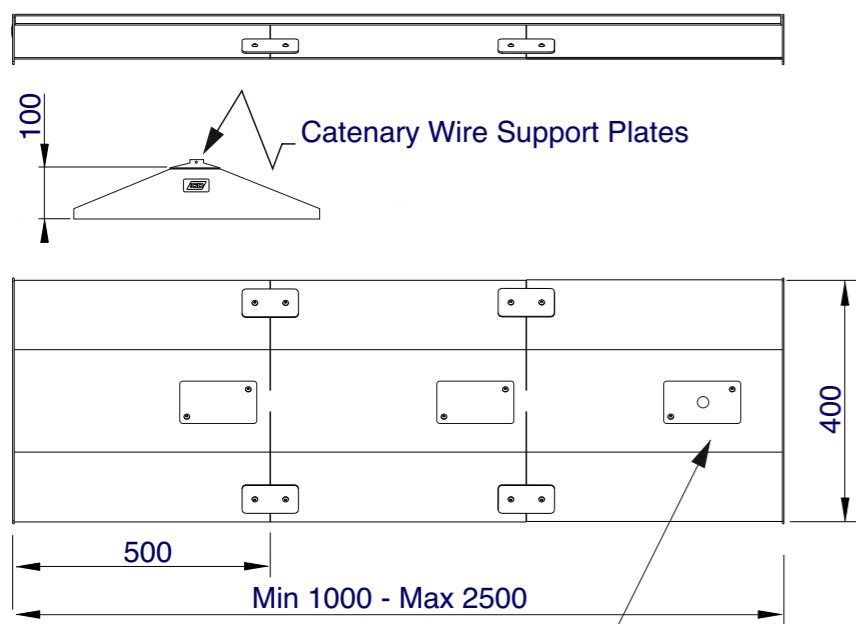

Available Sample Take off Points Bulkhead Provided for 6m OD x 4mm ID Polyurethane Tubing for Samplers, Direct Mount for 750 Series Detectors or Location Points for ATEX Detectors.

## ORDER CODES

Part Number	Description
TOC-GAS-05	Gas Hood Length 0.5M
TOC-GAS-HD	Gas Hood Length 1.0M
TOC-GAS-HD15	Gas Hood Length 1.5M
TOC-GAS-HD2	Gas Hood Length 2M
TOC-GAS-HD25	Gas Hood Length 2.5M
TOC-GAS-HD3	Gas Hood Length 3.0M
TOC-GAS-HD35	Gas Hood Length 3.5M
5150211	Hood Sample Point, Filter & Tubing

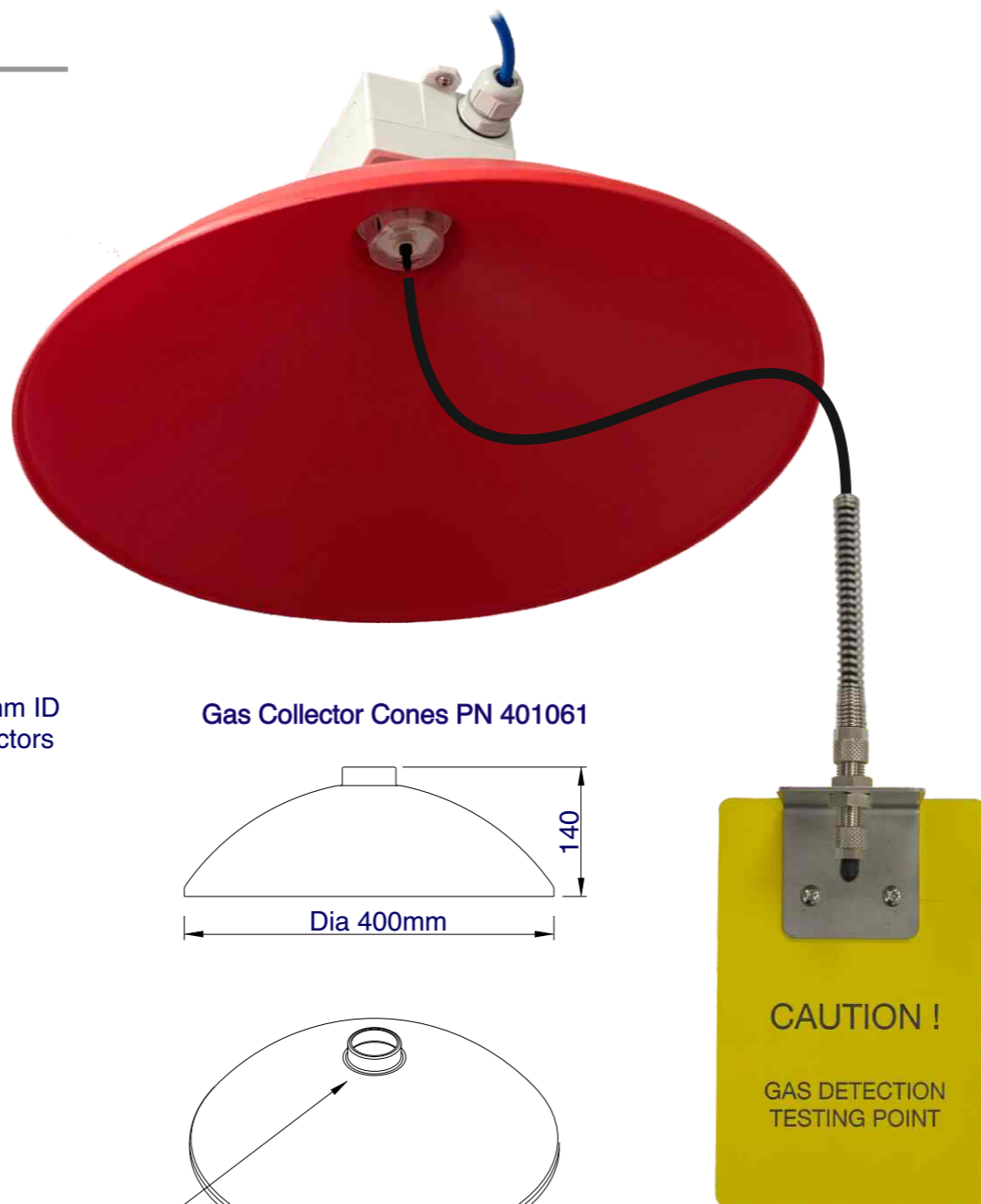

Gas Collector Cones PN 401061

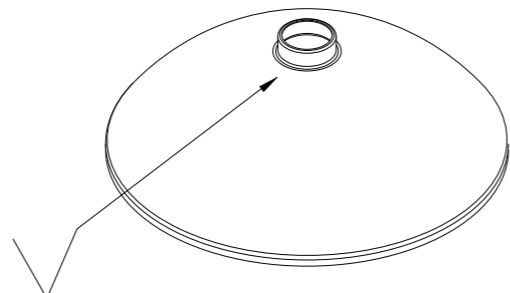
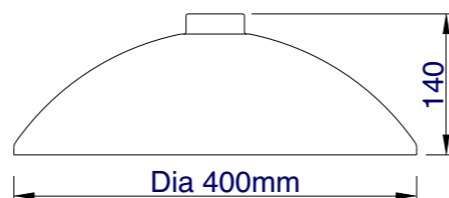

Note Requires Correct Adaptor To Fit Detector

Remote Gassing Port PN TOC-30-RMG

Use where mounting height of the detector makes calibration access a problem. Supplied with 6M of tubing, Clips, Bulkhead fitting and TOC-750-GD1

# GAS COLLECTOR CONES

Gas collector cones are available to fit all IGD Gas Detectors. They are typically used when detecting lighter than air gases to enhance detection capability. Collector cones are fitted to detectors placed over specific items of equipment where leaks may be expected. Some examples could be: boiler plant, valve stations, gas bottles, gas boosters, valve trains etc. Typically the detector fitted with its collector cone would be mounted 1.0 to 1.5M above the equipment to be monitored.



**TOCSIN 102 & 903**  
Order Collector Cone PN:401061 & Guard PN 401051



**TOCSIN 750 & 30**  
Detector Guard & Collector Cone Order PN: TOC-750-GD



**TOCSIN 750X**  
Order Collector Cone PN:401061 & Guard PN 401051

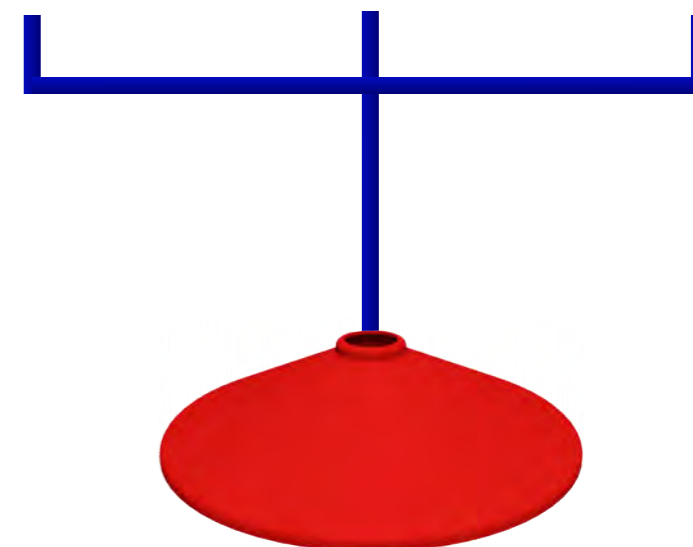

## SPECIFICATIONS

PN:	401451	PN:	TOC-750-GD1
Material	Acrylic/Delrin	Material	ABS
Temperature Range	See T102 Data	Temperature Range	See TOC-750 Data
Rating	To IP65	Rating	To IP55

## DIMENSIONS

401451 Splash Guard MKIII, 102 and Type B

TOC-750-GD1 Splash Guard

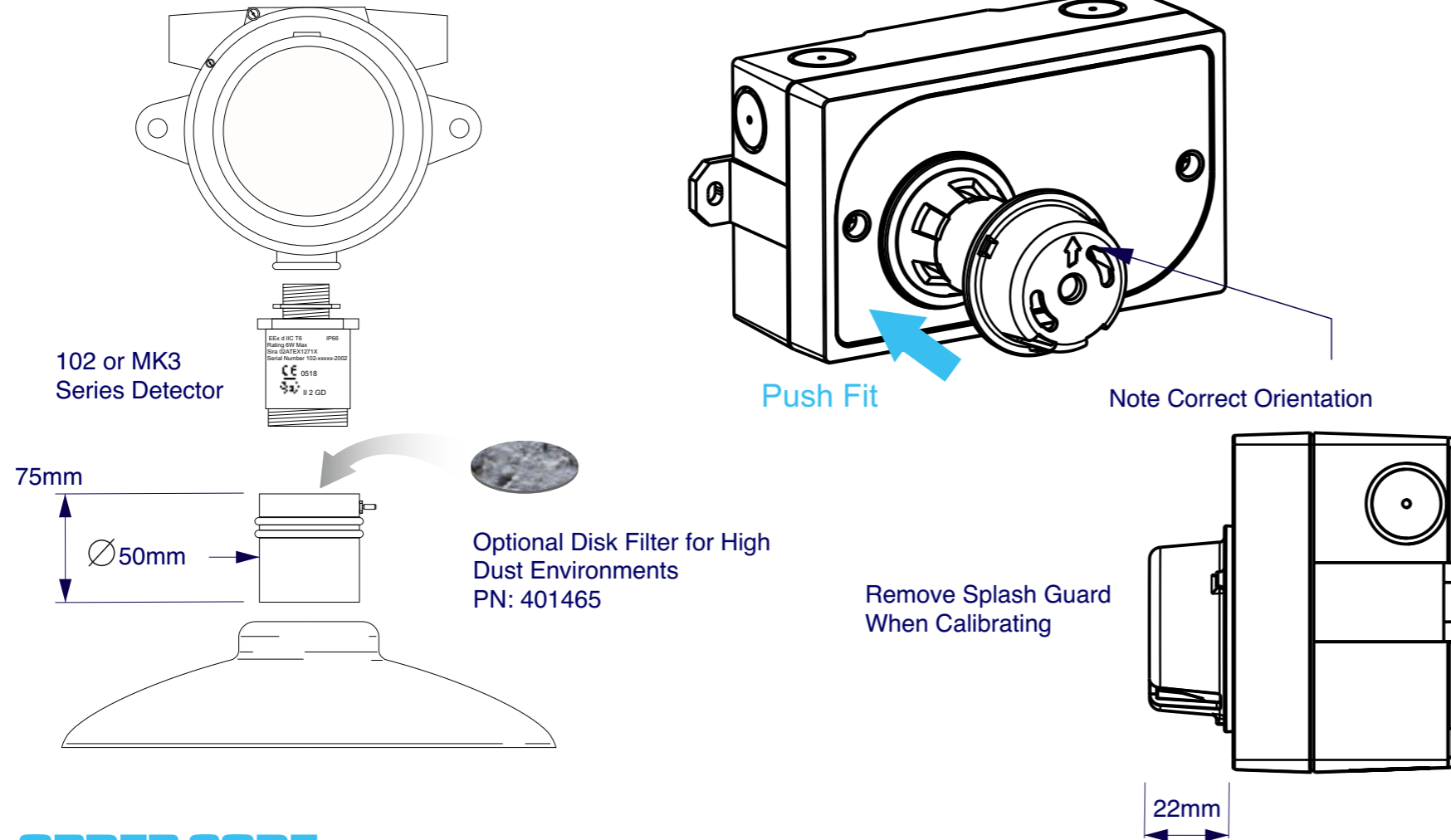

## ORDER CODE

Part Number	Description
401451	Weather Protection for MKIII, Type B & 102 Series Gas Detectors
TOC-750-GD	Collector Cone for 750 Series Detectors With Splash Guard
TOC-750-GD1	Splash guard for 750 Series Detectors
401465	Disk Filter

# SPLASH GUARDS

IGD has designed a range of state of the art Splash Guards to provide additional IP protection where required for detectors. These are used in areas where either splashes, dust or draught are a concern. These are designed to be easily installed with push or screw on fitting meaning minimal training is required.

In addition we also supply collector cones for lighter than air gases. These are fitted to sensor to aid the sensor in detection of lighter than air gases such as methane or hydrogen. The collector cone works by funnelling the gas to the sensor. These have been designed to be fitted with ease using the appropriate splash guard.



PN: 401451  
Note Calibration Port

Also use when fitting gas collector cones to ATEX detectors (PN:401061)



PN: TOC-750-GD1

*Please Note: Image for illustration purposes only*

## SPECIFICATIONS

Base Colour	Red	IP Rating	IP65
Lens Colour	Amber	Cable Entries	2 X 20mm
Audibility @ 1M	Up to 106 dB	Temperature	-25 deg C to 70 deg C
Tones	32	Rating	Continuous
Voltage	17-60V DC	Frequency	400 to 2850 Hz Selectable
Sounder Current	45mA Max	Construction	Flame Retardant Polycarbonate
Beacon Current	5mA		

## DIMENSIONS

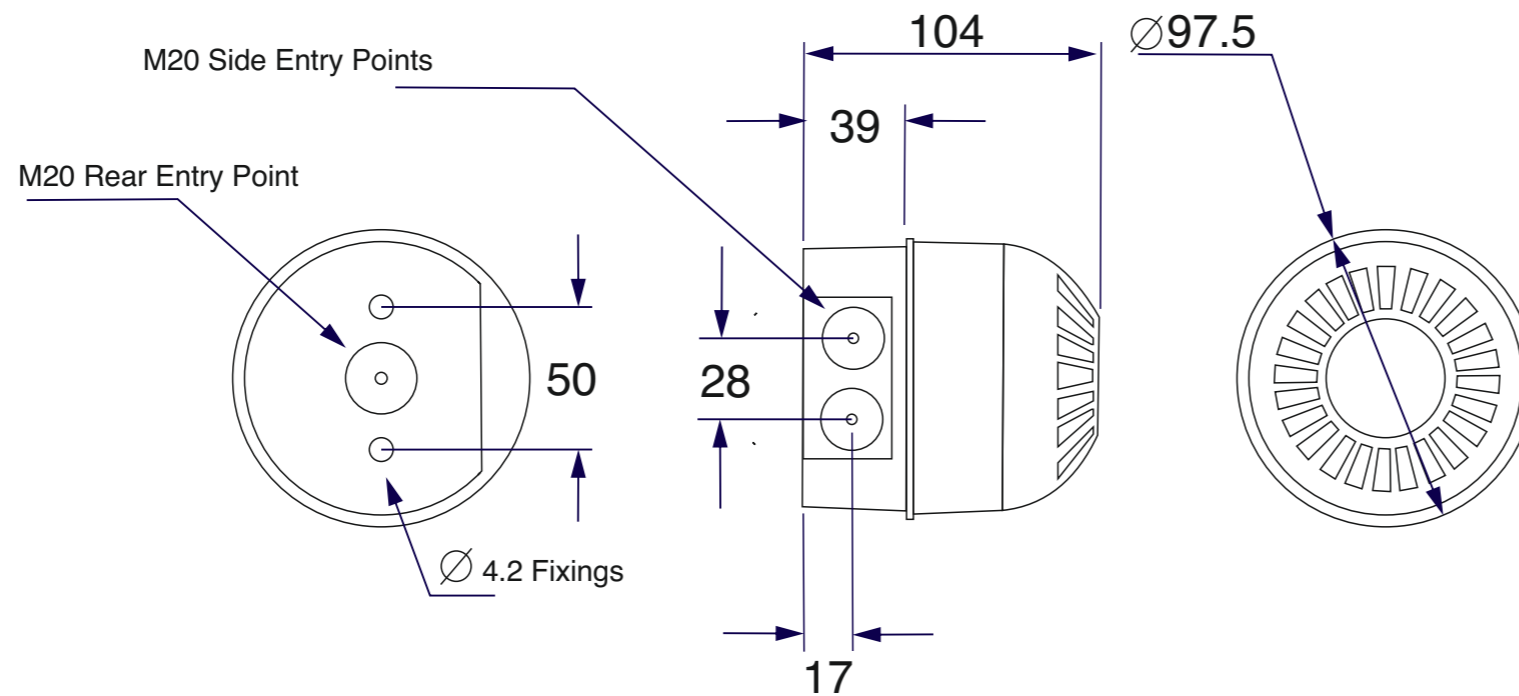

## ORDER CODE

Part Number	Description
5083101	Beacon Sounder 17-60BV DC Amber/Red

## BEACON SOUNDERS

IGD can supply beacon sounder(s)/Audible Visual alarms to enhance your systems safety features. They provide additional visual and audible signals to assist in alerting personnel and aiding evacuation, in the event of an alarm and are ideal for any situation. The beacon sounder(s) are also supplied with laser engraved signage to further indicate that the specified beacon is for a gas alarm. IGD believes it is best practice to place one beacon outside any entrance to the zone/area and appropriate numbers inside. This approach alerts persons inside an area to evacuate on alarm and provides warning at the entry points to the area. IGD beacon sounders can be wired directly to 750 series detectors. Setup allows for mutable sounders on alarm whilst leaving beacons running.



All IGD Beacon Sounders come with a laser cut legend plate, which can be customised for your needs.

## DIMENSIONS

Please Note: all measurements in mm

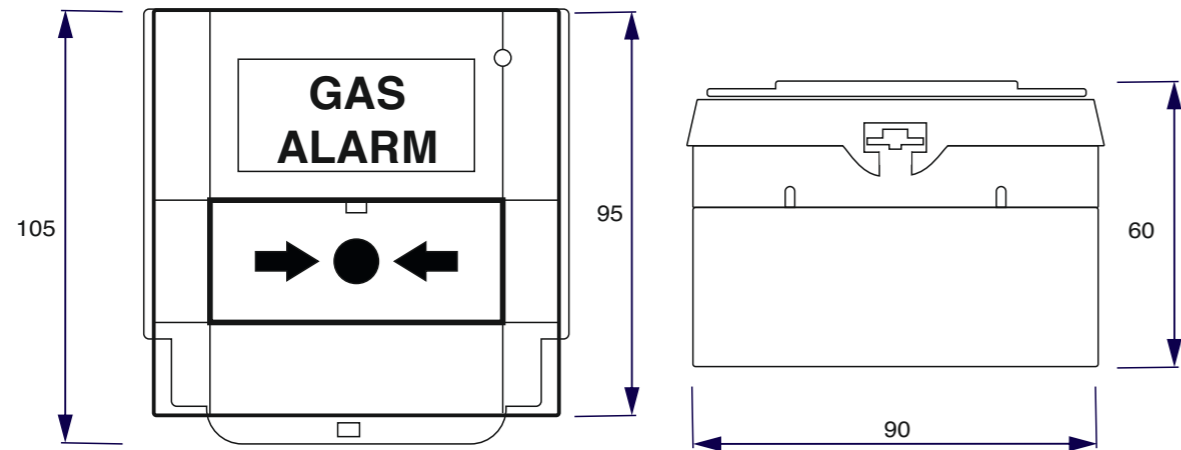

Please Note: all measurements in mm

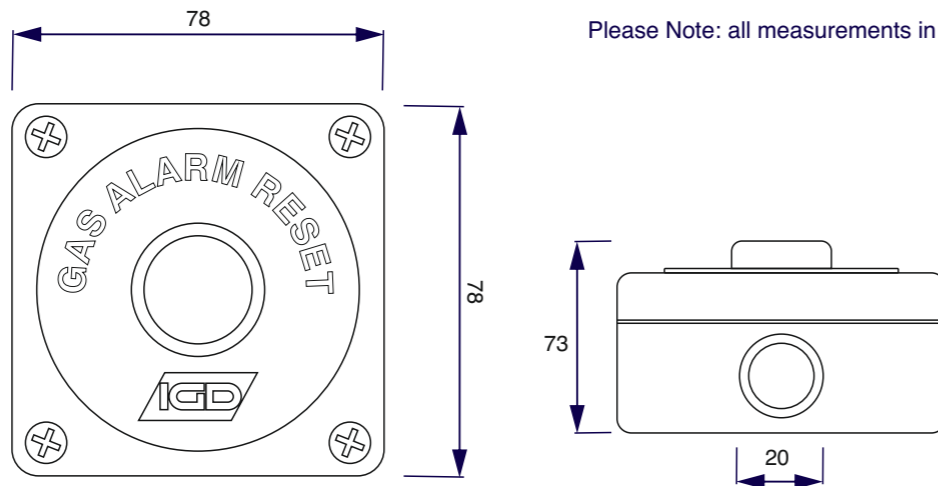

## ORDER CODE

Part Number	Description
ACC1001209	Wall Mount E-Stop Button
TOC-CALL-YELL	Yellow Call Point
TOC-750-CP2	Illuminated Call Point
TOC-RESET	Remote Reset Button



TOC-RESET



TOC-750-CP2



TOC-CALL-YELL

## CALL POINTS & RESET BUTTONS

IGD Call Points are designed to compliment IGD gas detection systems there are two versions of our emergency call points available.

TOC-750-CP2: This version offers illumination and a sounder option. Green when normal and red when triggered with optional sound alarm, clear indication of the call point status.

TOC-CALL-YEL: This version is a more conventional call point with mechanical indication only to show that it has been activated.

Both call points have protection shrouds and mechanical key reset. IGD Call Points easily interface to 750 series detector nodes as part of an integrated gas detection system.

IGD can provide remote reset buttons to go along side your fixed gas detection system. The remote reset button allows users to remotely reset a gas alarm activation without going back into the control panel. For large multi detector systems this can save time and improve site proficiency and safety.

## FEATURES

IGD Call Points and reset buttons are designed to be easy to install, working alongside IGD Systems. They interface directly to 750 Series Detectors and 750 Series Controllers.

IGD Call Points are illuminated, providing a visual indication when one has been tripped. They also have a built in audible alarm. This makes trip identification much easier.

Alternately a unit is available with mechanical trip indication.

Both units require a key to reset.

## DETAILS

## PITOT TYPE DUCT ADAPTERS

The Pitot duct adaptor relies on the gas velocity in a process to induce a flow in the probe to deliver gas to the gas detector. Typical applications are ventilation duct monitoring or air intakes in a variety of processes. With this type of unit the detector is remote from the Pitot assembly by tubing. This is particularly useful where mounting onto sheet metal duct work when access to the detector will still be required.

## SPECIFICATIONS

Materials	316St Stl, Norprene (PTFE Option), ABS
Tube Length	Max 150mm
Min Flow	3M-1
Max Flow	20M-1
Min Process Temp	3 Deg C
Max Process Temp	70 Deg C
Humidity	95%RH Non Condensing
Particulate	50mg/CU M

## ORDER CODES

Part Number	Description
5139002	Pitot Duct Adaptor For Use With 102 Series and MK3 ATEX Gas Detectors
TOC-30-DCT	Pitot Duct Adaptor for use with TOC-750 and TOC-30 Series Detectors, safe area



ATEX pitot adaptor image shown fitted to a 102 Series Detector  
PN: 5139002



Safe area pitot adaptor image shown on and off the detector  
PN: TOC-30-DCT

Duct Mounting Hole Detail

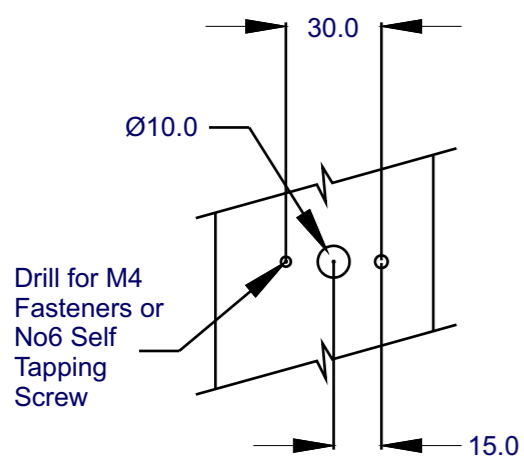

## APPLICATIONS

- Ventilation Duct Monitoring
- Air Intake Monitoring
- Process Extract Monitoring
- Abatement System Monitoring
- Glove Box Extract Monitoring

## DIMENSIONS

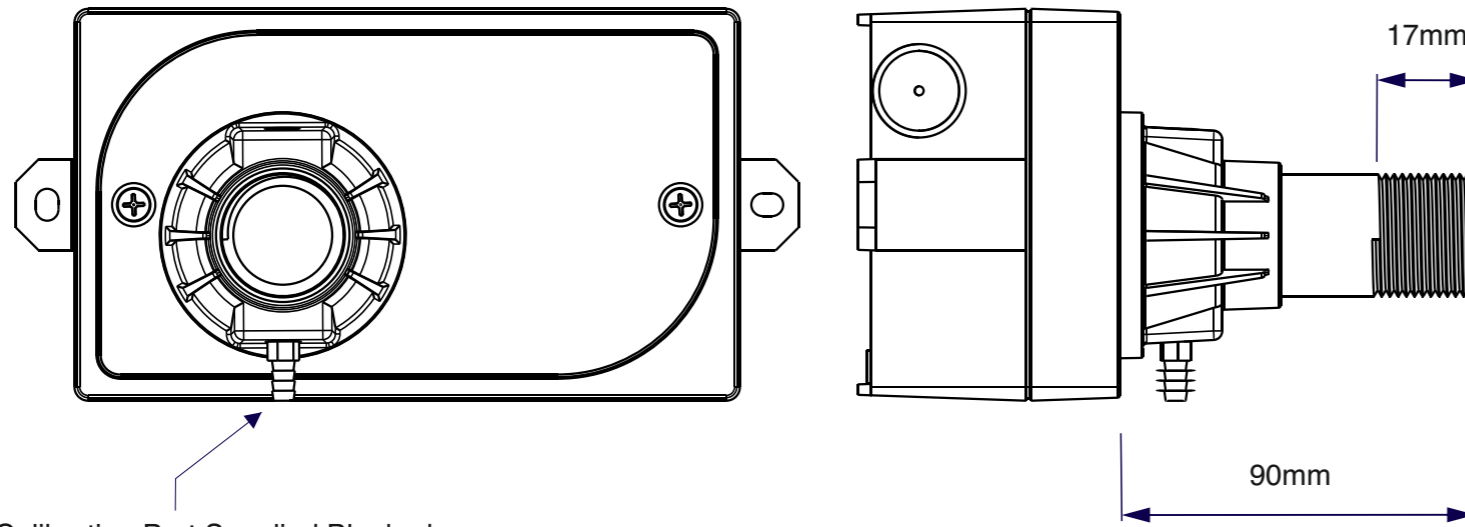

Calibration Port Supplied Blanked

## DIAGRAM

The below illustrates how a pipe in pipe adapter functions in a system with a T10-LPG-23RPR and the corresponding remote sensor.

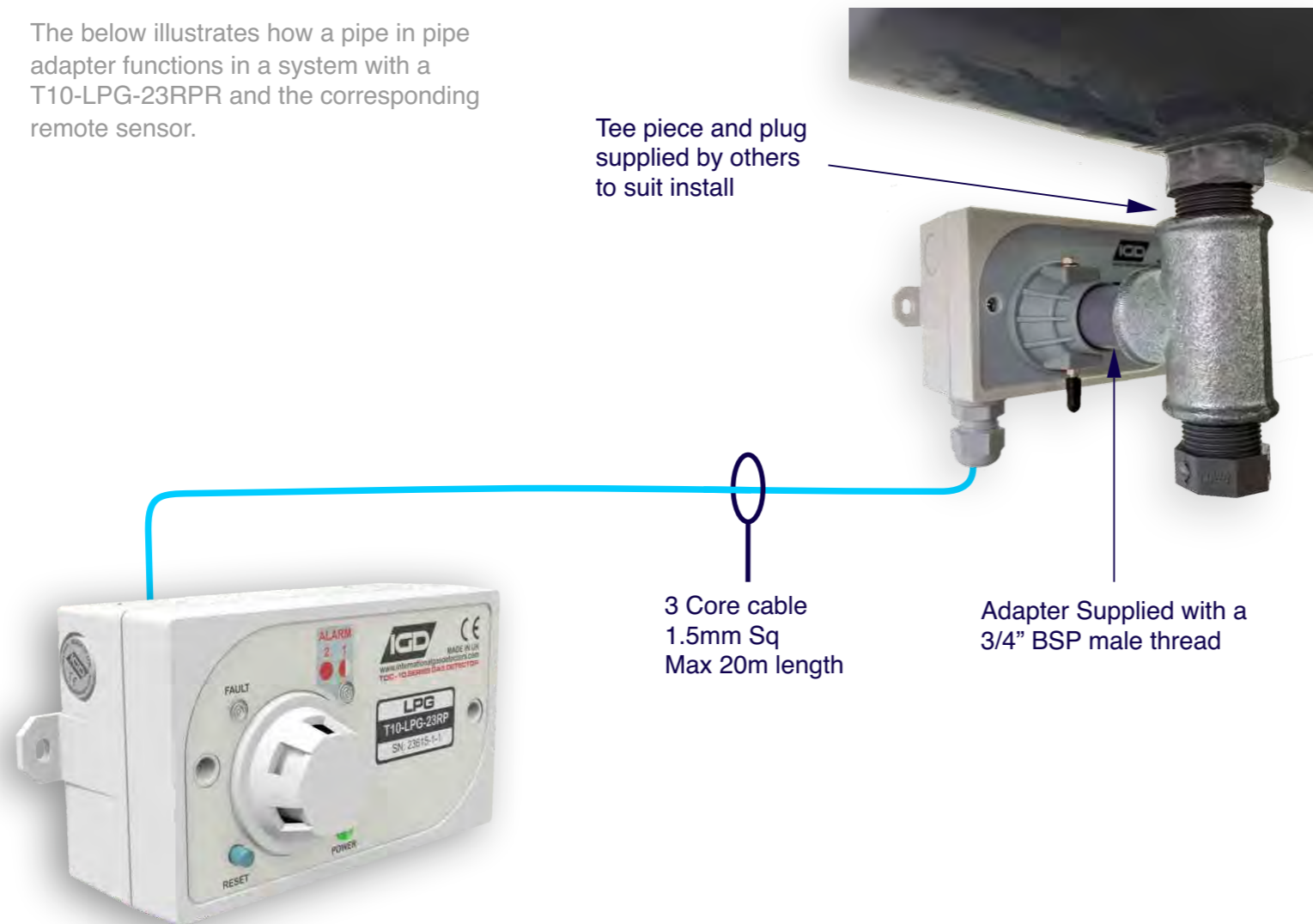

# PIPE IN PIPE ADAPTER

IGD's Pipe-in-Pipe adaptor is designed to enable detectors to monitor the interstitial gap in double containment pipe systems. The adaptor is supplied pre-fitted to either 750 Series, TOC-30 Series or TOC-10 Series Detectors. As indicated in the enclosed picture the sensor is mounted on a tee branched off from the underside of the containment pipe. A plug at the bottom of the tee seals the system and can be removed to vent the interstitial gap during maintenance and calibration. A calibration port is provided to allow an easy method to test the detector without removing it from the system. Note that the adaptor is supplied with a 3/4" male thread. Pipe fittings to mate to the outer containment pipe are not provide as these may vary depending on the containment system.

## ORDER CODE

Part Number	Description
T10-LPG-23RPR	Remote Sensor Version
TOC-750R-MK7	Remote Sensor
TOC-PIP	MK7 Pipe in Pipe Adaptor



**TOC-PIP**  
MK7 Pipe in Pipe Adaptor

## SPECIFICATIONS

Box Colour	White
Material	Aluminium Pressure Die Casting Max 0.5% Mg
IP Rating	IP68 (Silicone O Ring Lid Seal)
Entries	3 of M20 x 1.5
Construction	Flame proof EExd threads
Mounting	Wall Mounted
Weight	1.1 KG

## DIMENSIONS

Please Note: Mounting details shown with MKIII Gas Detector

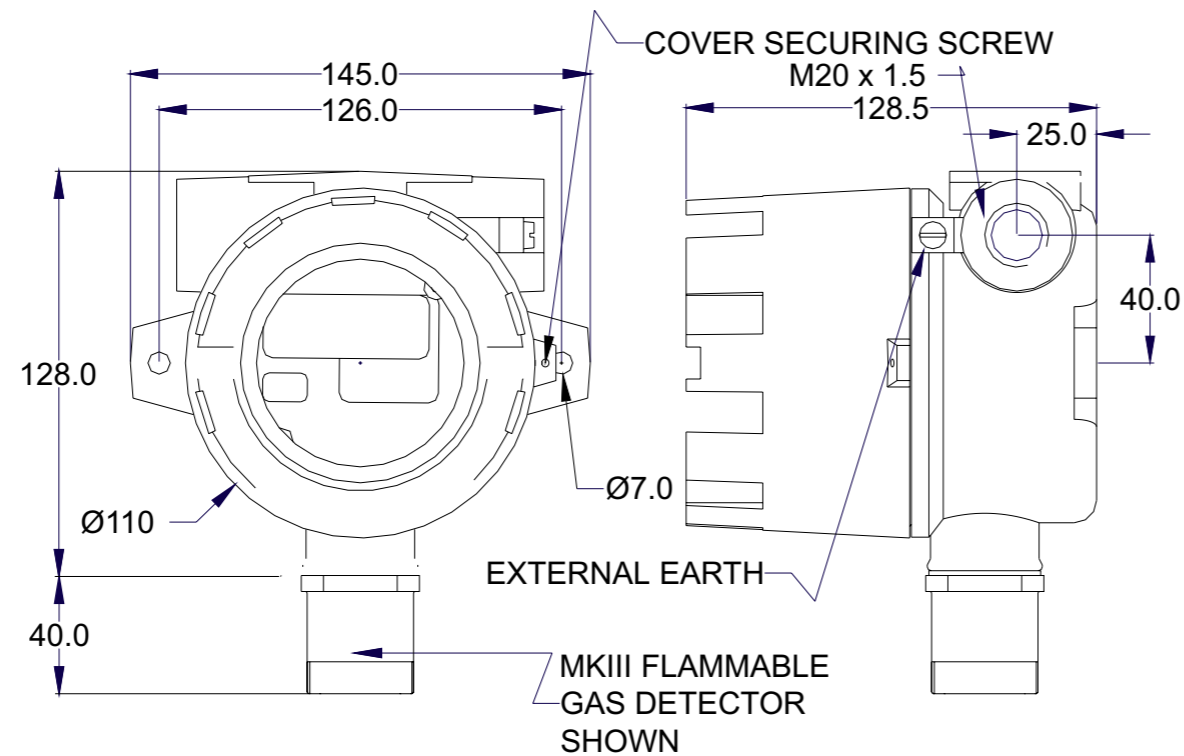

## ORDER CODE

Part Number	Description
5045802	Standard IGD ExD Junction Box ATEX 3 Terminals
5045803	316 Stainless Steel Version ATEX 3 Terminals

## ATEX JUNCTION BOXES

Our ATEX Junction Boxes allows you to mount our 102 or MKIII series ATEX sensors in zone 1 and 2 explosive areas and zone 21 and 22 dust environments. Further to this the ATEX Junction Box is also used for installing local nodes in the same environments. Giving distributed control in ATEX zoned areas.

To note, nodes allow you to control third party equipment such as local audible visual alarms, solenoid valves, 4-20mA input devices and more.

## APPROVALS

### JB3/903

II 2G Ex db IIC T6/T5 Gb  
 II 2D Ex tb IIC T85°C/ T100°C Db  
 Ta = -20°C to +40°C/+55°C  
 IECEx EXV 16.0002X  
 ExVeritas 16 ATEX 0140X  
 ExVeritas 21UKEX0913X  
 IP66 M20 x 1.5 Entries 12-32V DC  
 Compliant to IEC 60079-29-1



Please Note: Image for illustration purposes only



## DIMENSIONS

**Type 3 Duct Adaptor**  
**PN: 5133801**

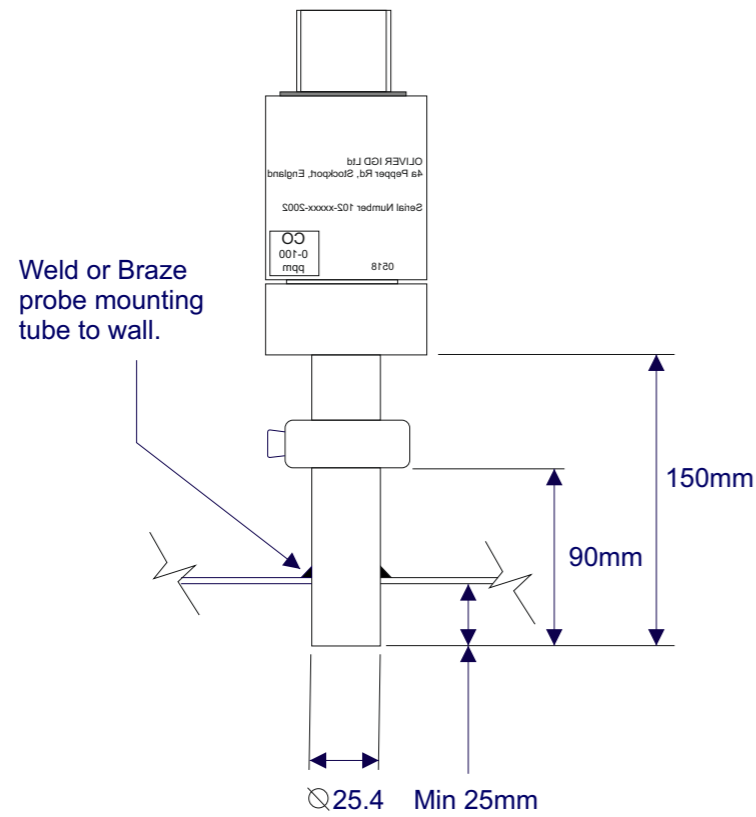

Adaptor PN:5133801  
Shown Fitted to 102  
Series Detector and  
750XD ATEX Display



## ATEX ENCLOSURE OR HEAD SPACE ADAPTERS

Type 3 duct adaptors rely on gas diffusion to the detector. Typical applications are head space monitoring in tanks, vessels or duct work. The clamp flange arrangement allows easy removal of the detector for service access and during fitment to the process. Internal baffles protect the detector and allow the optional fitting of filters if required.

Typical ATEX Applications Could Include:

- Vessel Head Space Monitoring
- Gas Storage Cabinet Monitoring
- Monitoring From Fume Hoods
- Through Wall Monitoring



## APPLICATIONS

**HEAD  
SPACE**

**CABINET**

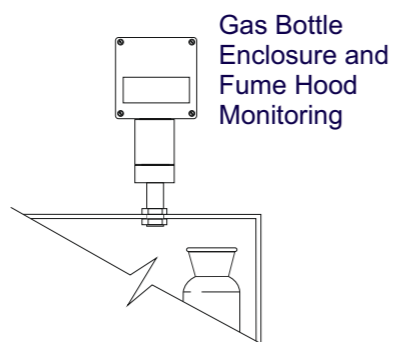
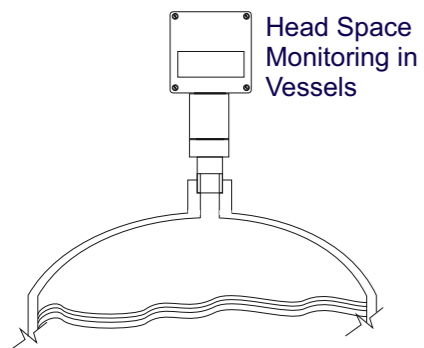

## ORDER CODE

Part Number	Description
5133801	Type 3 Duct Adaptor 25.4mm Tube End
5133601	Type 5 Duct Adaptor 1" BSP Tube End

## SPECIFICATIONS

Materials	316St Stl, Silicone
Tube Length	Max 150mm
Min Temp	-20 Deg C (general see detector specification)
Max Process Temp	+55 Deg C (general see detector specification)

## PROFESSIONAL CALIBRATION KITS & GAS BOTTLES

Part Number	Description	Part Number	Description
5137201	Calibration Gas Bottle as; 50ppm CO, 1% CH4 (20% LEL), 18% Oxygen, 5000ppm CO2	5137201R	Calibration Gas Bottle as; 50ppm CO, 1% CH4 (20% LEL), 18% Oxygen, 4000ppm Co2
	Zero Gas Bottle, Nitrogen	5141801	25ppm H2S
	Adapters, Hose, Regulator, Case	5142402	10ppm Isobutylene
5142301	Calibration Gas Bottle as; 25ppm Iso-Butylene	5142401	3000ppm Isobutylene
	Zero Gas Bottle, Nitrogen	5115001	10ppm NO2
	Adapters, Hose, Regulator, Case	5114101	25ppm NO
5124601	Calibration Gas Bottle as; 3000ppm Iso-Butylene	5141901	1000ppm R134
	Zero Gas Bottle, Nitrogen	5142201	Nitrogen
	Adapters, Hose, Regulator, Case	5142501	20% LEL Butane
		5142101	1800ppm Hydrogen
		5139301	Instrument Grade Air

## BUMP TEST KITS & GAS BOTTLES

Part Number	Description	Part Number	Description
TOC-GAS-KIT	Calibration Gas Bottle as; 50ppm CO, 1% CH4 (20% LEL), 18% Oxygen, 4000ppm CO2	TOC-GAS-MIX	Calibration Gas Bottle as; 50ppm CO, 1% CH4 (20% LEL), 18% Oxygen, 4000ppm Co2
	Zero Gas Bottle, Nitrogen	TOC-GAS-N2	Zero Gas Bottle, Nitrogen
	Adapters, Hose, Regulator, Case		

## SPARES

Part Number	Description
5022001	Regulator for Professional Kit
5033001	Flow Valve for Bump Test Kit
4011109	Calibration Adapter for TOC-10, TOC-30, MK7 Detectors
401101A	Calibration Adaptor for 102 Series Detectors
4011103	Calibration Adaptor for Mk6 Detectors
401101B	Calibration Adaptor for 103 Series Detector
401101F	Calibration Adaptor for 101 Series Freon Detector
401101Z	Calibration Adaptor for Zirconia Probes (Tocsin 950)

# CALIBRATION KITS & GAS BOTTLES

IGD provide gas calibration kits and replacement gas bottles to support our range of gas detectors. Kits are available as either Professional Kits or user Bump Test Kits

Bump Test Kits are intended for clients who want to test or prove detector operation but not necessarily calibrate (bump test). Bottles supplied are 1L water volume cylinders typically containing 12L of compressed gas. These bottles contain enough gas for 6+ Tests. Kits are supplied with a full set of IGD detector calibration gas adaptors, flow valve and hose. The set is supplied in a storage case. Each kit is supplied with a bottled calibration gas and zero gas, usually pure Nitrogen.

Professional Kits are intended for engineers who undertake regular calibration of detectors as part of a traceable calibration operation. Bottles supplied are 1.55L water volume cylinders typically containing 112L of compressed gas. These bottles typically contain enough gas for 80+ calibrations. Kits are supplied with a full set of IGD detector calibration gas adaptors, 0.5L per Minute flow regulator and hose. The set is supplied in a storage case capable of housing up to 3 gas bottles. Each kit is supplied with a bottled calibration gas and zero gas, usually pure Nitrogen.



Typical Professional Cal Kit



Typical Bump Test Kit